

LOW PROFILE CYLINDERS WITH SAFETY RING NUT, LOAD RETURN

FEATURES

Pancake lock ring cylinders have an overflow port to limit stroke. The rod on these cylinders has a coloured area which appears 10mm before the maximum stroke has been reached. This version does not conform to ANSI B30.1.

These cylinders are particularly suited to applications where the load has to be left in a raised position for long periods. The load can be supported by the safety lock nut, this allows the pressure to be released and the pumps and hoses can be disconnected until it is necessary to lower the load.

All cylinders are supplied with integrated tilt saddle and eyelets for ease of transport.

OPERATIONAL AREAS

CGR cylinders are ideal for use in the construction and maintenance of bridges, viaducts, building sites and industrial maintenance where working space is limited.

The protective nitriding treatment on these cylinders gives excellent resistance to corrosion making them suitable for use in aggressive environments.



STANDARD

Integrated tilt saddle, reducing the effects of possible off-centred loads.



CGR cylinders have been designed for use in applications where space is limited and to stand the full load even without a pressure distribution plate below. It is anyhow recommended that pressure plates are placed both under the base and on top of the saddle to distribute the load if the support resistance is not compatible with the pressure shown in the chart.

Non compliance with this notice could result in damage to the cylinder and/or the load being lifted.



During the lifting operation the operator must always be in a position to observe when the coloured end of stroke section of the rod appears.

LOW PROFILE CYLINDERS WITH SAFETY RING NUT, LOAD RETURN

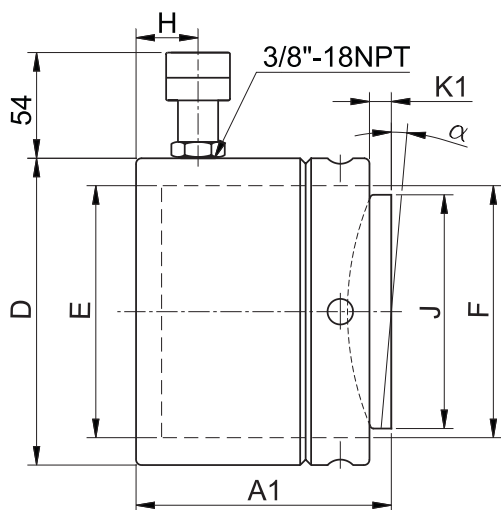

- Force 110 - 900 t
- Stroke 50 mm
- Max working pressure 700 bar

SELECTION CHART

Pushing force	Stroke	Oil volume	Cylinder bottom pressure	Saddle pressure	MODEL	Closed height with integrated tilt saddle	External Dia.	Piston Dia.	Rod Dia.	Coupler height	Tilt saddle Dia.	Rod projection with integrated tilt saddle	Tilt saddle angle	Weight
						A1 mm	D mm	E mm	F mm	H mm	J mm	K1 mm	α	kg
110 1078	50	770	46	113	CGR110N50	137	178	140	Tr 140x10	19	118	8	5°	26
160 1589		1135	45	102	CGR160N50	148	218	170	Tr 170x10	19	148	9	5°	42
200 1985		1418	45	87	CGR200N50	154	242	190	Tr 190x10	20	176	10	5°	54
250 2424		1732	45	84	CGR250N50	159	268	210	Tr 210x10	22	196	11	5°	68
400 4008		2863	44	89	CGR400N50	178	347	270	Tr 270x10	27	248	11	4°	128
500 4948		3534	44	81	CGR500N50	192	385	300	Tr 300x10	30	285	10	3°	171
700 6735		4811	44	85	CGR700N50	200	445	350	Tr 350x10	30	325	10	3°	238
900 8796		6283	47	83	CGR900N50	216	495	400	Tr 400x10	30	375	12	3°	315

* Nominal value, see kN for the exact force