

LOW PROFILE CYLINDERS, SPRING RETURN

FEATURES

Low closed height compared to stroke. **CMP** cylinders have the longest stroke in the spring return pad jack range.

All cylinders have a grooved rod top for improved load grip and there are two threaded holes for mounting a tilt saddle. This is recommended where there is a danger of sideloading. Wiper seals are fitted to prevent the penetration of dirt. Base mounting holes are also available as an optional extra.

OPERATIONAL AREAS

The small dimensions and the complete treatment against corrosion makes these cylinders ideal for all lifting, levelling, support and pressing operations in restricted working areas and/or tough environments.

General maintenance work, industrial assembly and construction are among the most common applications for this type of cylinder.

p. 31

ACCESSORIES



- **Separate ZTT tilt saddle**, reduces the effects of possible off-centred loads.



STANDARD



- Tilt saddle mounting **holes**.

OPTIONS



- **F - Version**, cylinder with base mounting **holes** for fixing purposes.



Follow our safety instructions.
See useful pages.

p. 126

LOW PROFILE CYLINDERS, SPRING RETURN

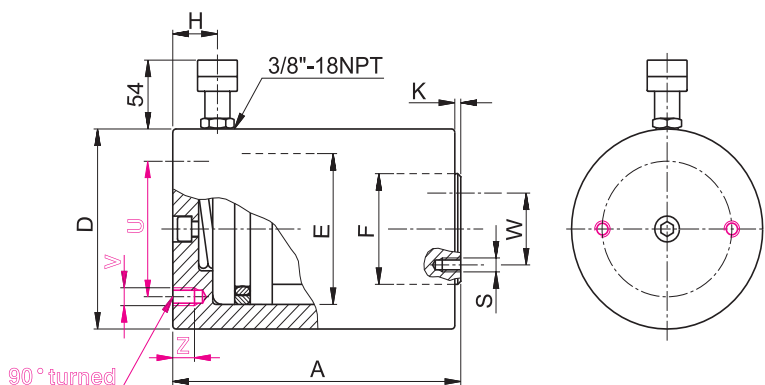

- Force **10 - 100 t**
- Stroke **25 - 50 mm**
- Max working pressure **700 bar**

Cylinders with non standard **force** and **stroke** can be supplied upon request

SELECTION CHART

Pushing force	Stroke	Oil volume	MODEL	Closed height	External Dia.	Piston Dia.	Rod Dia.	Coupler height	Rod projection	PCD mounting holes	Mounting holes_Depth	PCD mounting holes for the tilt saddle	Mounting holes for tilt saddle	Weight
				A	D	E	F	H	K	U	V/Z	W	S	kg
10 111	25	40	CMP10N25	72	75	45	35	19	1	25	2xM8	24	2xM5	2,5
	50	80	CMP10N50	97							6			3,2
20 198	25	71	CMP20N25	75	88	60	45	19	1	60	2xM10	34	2xM5	3,4
	50	141	CMP20N50	100							10			4,2
30 309	25	110	CMP30N25	86	102	75	55	19	1	65	2xM10	44	2xM5	5,0
	50	221	CMP30N50	111							13			6,1
50 496	25	177	CMP50N25	97	127	95	80	22	1	95	2xM12	65	2xM6	7,6
	50	354	CMP50N50	122							15			9,1
100 929	25	332	CMP100N25	116	175	130	100	22	2	140	2xM12	65	2xM6	17,6
	50	664	CMP100N50	141							17			20,5

* Nominal value, see kN for the exact force

ACCESSORIES: ZTT TILT SADDLES

MODEL	For use with	a	b	j	z	w	kg
ZTT10	CMP10N # #	16	1	34	5,5	24	0,1
ZTT20	CMP20N # #	18		43		34	0,2
ZTT30	CMP30N # #	19		53	44	0,3	
ZTT50	CMP50N # #	25	2	68	6,5	65	0,9
ZTT100	CMP100N # #	34		88			1,7

MODEL CODING

CMP	10	N	# #	#
Series	Pushing force in tonne	N = standard	Stroke in mm	F = with base mounting holes