



**Hidro
Pnevmo
Tehnika**

3, Vojeli St., Kazanlak, Bulgaria
Tel.: +359 431/ 62 228
e-mail: info@hpt-bg.com
www.hpt-bg.com

SOLENOID OPERATED DIRECTIONAL CONTROL VALVE

. RS06 C ... / ..-2

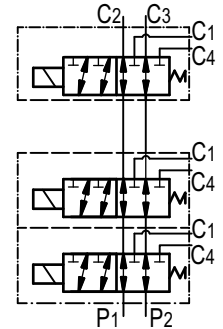
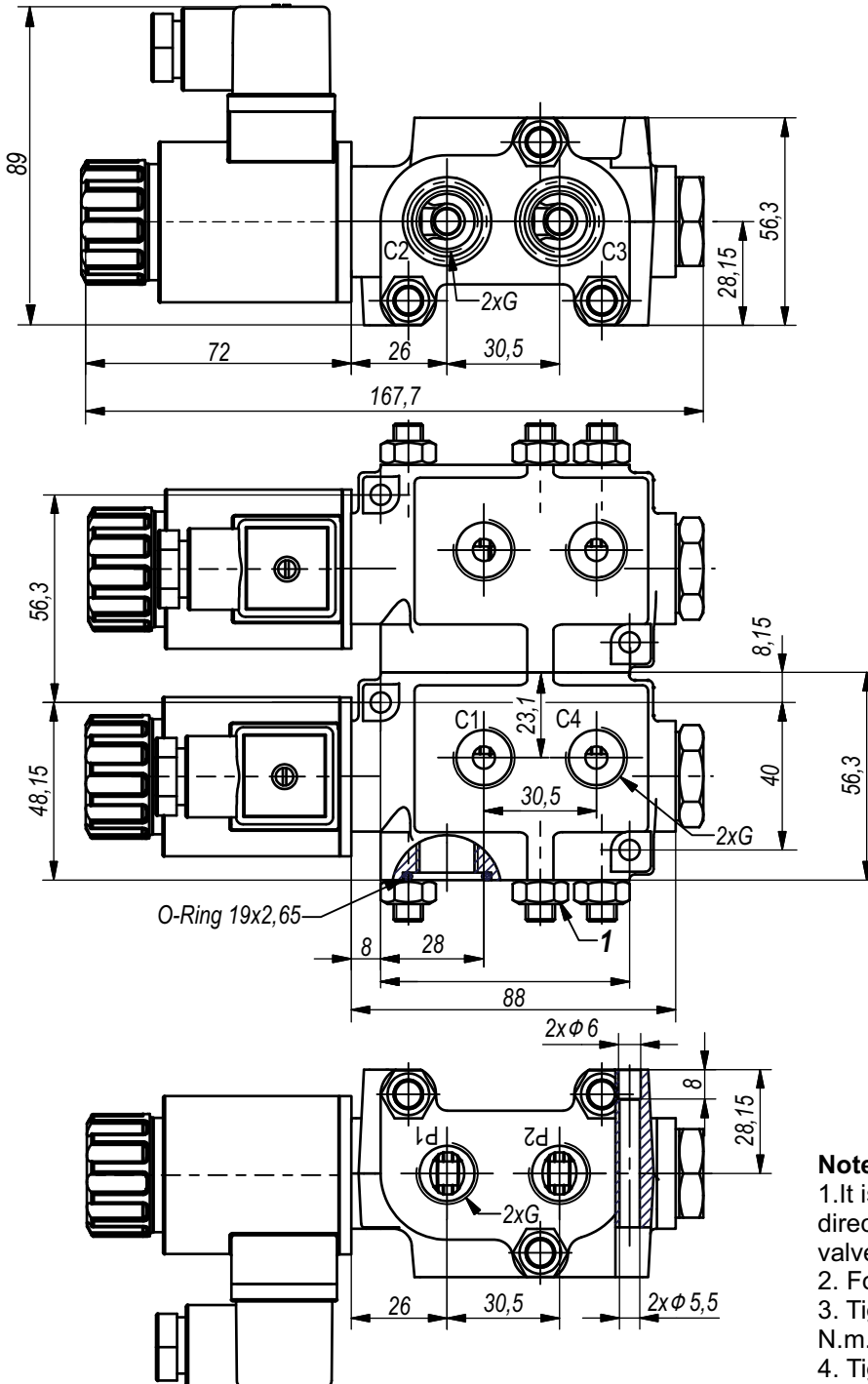

Note:

1. It is possible to make stacks with up to 8 directional control valves. A stack with 2 valves is shown.
2. For technical data see page 1.3.
3. Tightening torque for the solenoid - 25 N.m.
4. Tightening torque for the nuts (position 1) - 20...23 N.m.

ORDERING CODE

RS06C 38 / 12 - 2

Series

Number of sections: **2...8**

Type

Port threads "G" - code:
G3/8" - 38

Operating voltage - code:
12V / 00Hz - 12
24V / 00Hz - 24
110V/50Hz - 110
220V/50Hz - 220