



**Hidro
Pnevmo
Tehnika**

3, Vojeli St., Kazanlak, Bulgaria
Tel.: +359 431/ 62 228, 68 440
e-mail : info@hpt-bg.com
www.hpt-bg.com

SOLENOID OPERATED DIRECTIONAL CONTROL VALVE

RS 06 ... / ..-2

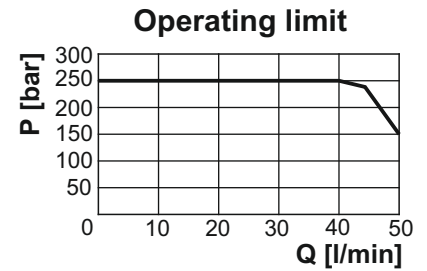
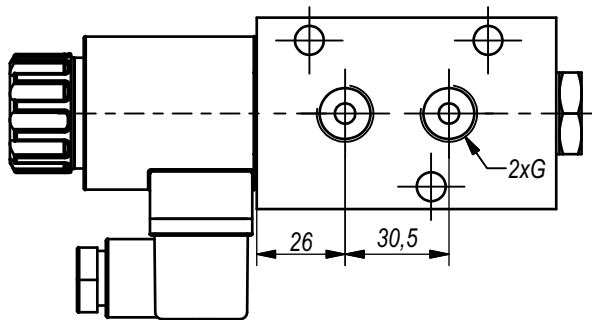
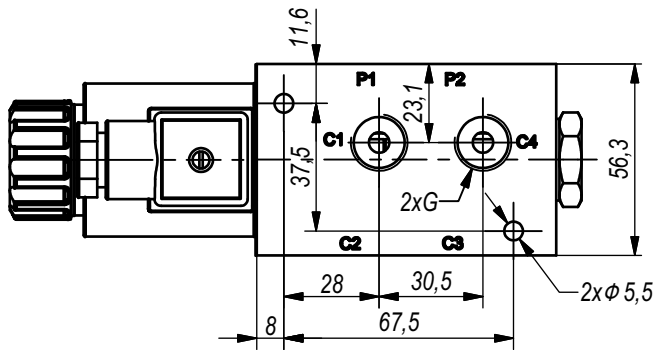
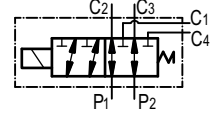
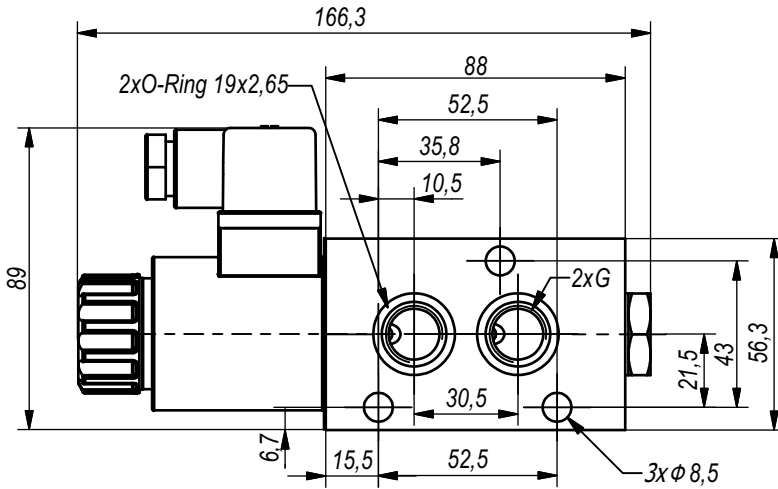
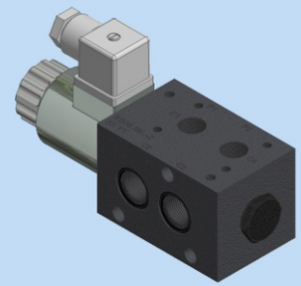

Internal leakage - 20 cm³/min
mineral oil with 46 cSt viscosity
and at 100 bar pressure

TECHNICAL DATA

General		
Ambient temperature	°C	-20...+50
Hydraulic		
Maximal pressure	bar	250
Maximal flow rate	L/min	50
Working fluid - mineral oil		
- viscosity	mm ² /s	10...100
- filtration level	µm	25 or better
- temperature	°C	-20...+80
Power supply		
Voltage	V DC	12±5%
		24±5%

Note:

- All performances and calibration are carried out by using hydraulic oil with viscosity approx 46 cSt at 50 °C.
- Tightening torque for the solenoid - 25 N.m.

ORDERING CODE

RS06 38 / 12-2

Type

Port threads "G" - code:
G3/8" - 38

Series

Operating voltage - code:
12V / 00Hz - 12
24V / 00Hz - 24
110V/50Hz - 110
220V/50Hz - 220