

A88... MODULAR FLOW CONTROL VALVES

FAST / SLOW ASSEMBLY CETOP 5

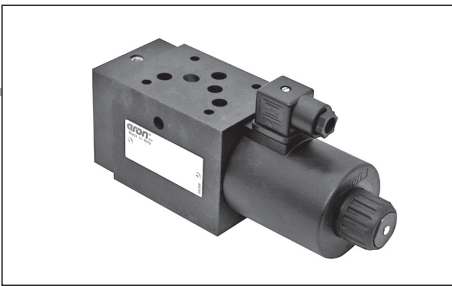

This is a modular assembly ON/OFF solenoid valve which, by fitting a suitable 2 way regulator, allows two speed operation in the same system via an electrical changeover command.

Max. operating pressure	320 bar
Hydraulic fluids	Mineral oils DIN 51524
Fluid viscosity	10 ÷ 500 mm ² /s
Fluid temperature	-25°C ÷ 75°C
Ambient temperature	-25°C ÷ 60°C
Max. contamination level	class 10 in accordance with NAS 1638 with filter $\beta_{25} \geq 75$
Weight with a DC solenoid	4,2 Kg

The flow rate regulator type QC32 must be ordered separately.
The limit of use curves have been obtained with the regulator fully closed, and those same limits improve gradually with the opening of the regulator.

The test have been carried out at operating temperature, with a voltage 10% lower than rated voltage and with a fluid temperature of 50 degrees C. The fluid used was a mineral based oil with a viscosity of 46 mm²/sec at 40 degrees C.

• Solenoids used are standard type A16 for DC voltage.

A88...	
"A16" DC COILS	CH. I PAGE 40
STANDARD CONNECTORS	CH. I PAGE 20
QC32...	CH. III PAGE 2
SCREWS AND STUDS	CH. IV PAGE 36

ORDERING CODE

4

A	Speed control valve
88	Size
E	Electrical operator
***	120 = Normally open 121 = Normally closed See table "Hydraulic symbols"
*	Control on lines A/B/P/T (see symbols) The interface holder "H" must be turned by 180° in order to obtain the A1 and B1 versions.
*	Voltage : see tab.1
**	Variants: see tab.2
3	Serial No.

LIMITS OF USE DC SOLENOID

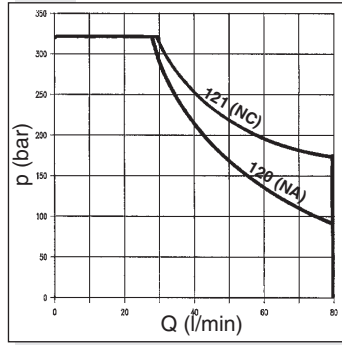

FREE FLOW THROUGH SPOOL

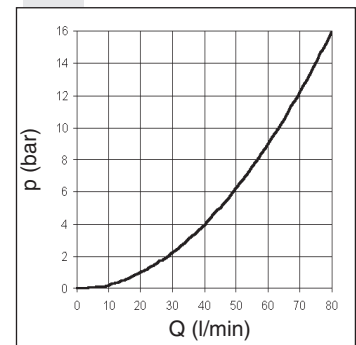

HYDRAULIC SYMBOLS

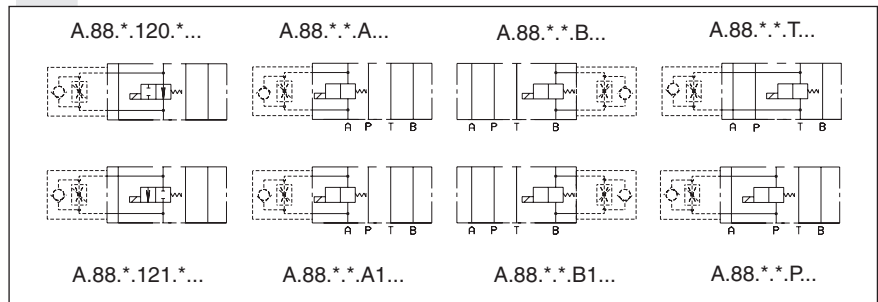

TAB.1 - A16 COIL (45W)

DC VOLTAGE **

L	12V	115Vac/50Hz 120Vac/60Hz with rectifier
M	24V	
N	48V*	230Vac/50Hz 240Vac/60Hz with rectifier
P	110V*	
Z	102V*	
X	205V*	
W	Without DC coil	

Voltage codes are not stamped on the plate, they are readable on the coils.

* Special voltage

** Technical data see Ch. VII • 7

TAB.2 - VARIANTS

No variant (without connectors) S1(*)
 Viton SV(*)

Other variants available on request

(*) Coils with Hirschmann connection supplied without connectors. The connectors can be ordered separately, Ch. I • 20.

