

# AD3XD... DIRECTIONAL CONTROLE CETOP 3

IN ACCORDANCE WITH 2014/34/UE ATEX DIRECTIVE 



**SOLENOID VALVES FOR USE IN WORKPLACES WHERE EXPLOSIVE ATMOSPHERES MAY OCCUR DUE TO THE PRESENCE OF GAS, VAPOUR OR MIST AND DUST.**

1

## AD3XD...

ATEX DIRECTIVE	CH. I PAGE 23
ATEX CLASSIFICATION	CH. I PAGE 24
SERIES AD3XD...	CH. I PAGE 25
TECHNICAL SPECIFICATIONS	CH. I PAGE 25
ORDERING CODE	CH. I PAGE 25
TAB.1 ASSEMBLY	CH. I PAGE 26
TAB.2 VOLTAGES	CH. I PAGE 26
TAB.3 SPOOL	CH. I PAGE 26
LIMITS OF USE	CH. I PAGE 26
IDENTIFICATION NAMEPLATE	CH. I PAGE 27
SAFETY INSTRUCTIONS	CH. I PAGE 27
OVERALL DIMENSIONS	CH. I PAGE 28

AD3.XD solenoid valves are classified in:

**Group II** appliances (to be used in workplaces, apart from mines, where there is the probability of explosive atmospheres);

**Category 2** (high protection level), for use in workplaces where it is probable that an explosive atmosphere may form in normal working conditions and classified by the presence of explosive mixtures of gas-dust type (letter **GD**) for zones **1, 2** and **21, 22**.

**Group I** (They are intended to be used in mines with gas firedamp);

**Category M2** (high level of protection), they are intended for use in underground environment in mines and their surface installations, exposed to the likely risk of the release of firedamp and / or combustible dust under normal operating conditions.

These valves are therefore designed especially and manufactured in compliance with the ATEX 2014/34/UE Directive and according to European regulations EN 1127-1, EN 1127-2, EN 13463-1 and EN 13463-5.

Belonging to the "NG06 direction control" of Aron range, these valves are prepared for plate-mounting with attachment surface in compliance with UNI ISO 4401 - 03 - 02 - 0 - 94 (former CETOP R 35 H 4.2-4-03). They are activated electrically and the centre position is ensured by springs with gauged lengths, which once the pulse or command ceases, re-position the spool in the centre or at the end of travel position.





The coils used for these valves are subject to separate conformity certification, according to the ATEX Directive (EC-type). For further specifications, please consult the documents that are always supplied with the valve.

Before marking and marketing the valves of the AD3XD series, undergo tests and inspections according to the in-house Manufacturing System and to the Certified Company Quality System in compliance with ISO 9001:2008. All of the AD3XD valve series undergo 100% functional testing. These tests and inspections guarantee that the products sold comply with all the information reported in the Technical Specifications File registered and declared by marking with AD3X/ATEX/10.

## ORDERING CODE

<b>AD</b>	Directional Control Valve
<b>3</b>	CETOP 3/NG06
<b>XD</b>	Solenoid valves built pursuant to ATEX Directive-2014/34/UE. With coils in explosion-proof version (Ex d) and IECEx conformity marked
<b>**</b>	Spools <b>01/02/03/04/16</b> (tab.3). For further hydraulic diagrams, contact Aron Customer Service
<b>*</b>	Assembly <b>C / E / F / G / H</b> (tab.1). For further assembly instructions, contact Aron Customer Service
<b>*</b>	Voltage (tab.2)
<b>**</b>	Variants <b>00</b> = None <b>V1</b> = Viton <b>LE</b> = Emergency lever <b>T6</b> = Suitable for temperature class I M2 Group T6 (<85°C) (mine)
<b>2</b>	Serial number

## TECHNICAL SPECIFICATIONS

Description	AD3XD...	T6 version (mine)
<b>Valve marking</b>	  II 2GD/I M2 cT5	  II 2 GD/I M2 cT6
Max. pressure on lines P/A/B	320 bar	320 bar
Max. pressure on line T (dynamic)	250 bar	250 bar
Max. flow rate	60 l/min	60 l/min
Max. excitation frequency	3 Hz	3 Hz
Duty cycle	100%ED	100%ED
Hydraulic fluids	mineral oils DIN 51524	mineral oils DIN 51524
Fluid viscosity	10 ÷ 500 mm <sup>2</sup> /s	10 ÷ 500 mm <sup>2</sup> /s
<b>Fluid temperature (*)</b>	<b>-20°C ÷ +40°C</b>	<b>-20°C ÷ +40°C</b>
<b>Ambient temperature</b>	<b>-20°C ÷ +40°C</b>	<b>-20°C ÷ +40°C</b>
Max. contamination level	NAS 1638: class 10 with filter β <sub>25</sub> ≥ 75	NAS 1638: class 10 with filter β <sub>25</sub> ≥ 75
Weight (one solenoid)	2,37 kg	2,37 kg
Weight (two solenoids)	3,82 kg	3,82 kg
Solenoid rated power:	6,5 ÷ 11W	
Degree of protection:	IP 67	
Power supply tolerance:	±10%	
Power supply cable:	standard length 3 m with cable gland	
Solenoid marking (**):	consult documents supplied with solenoid	
Surface temperature:	function of the power. Consult documents supplied with solenoid.	

(\*) For use with different hydraulic fluids, which do not constitute an effective ignition source in potentially explosive atmospheres IIC across the range of temperatures and pressures required by the unit marking, consult the technical department.

(\*\*) Solenoid is provided with marking for protection class according to Explosion Protection Directive ATEX-2014/34/UE and IECEx certificate of conformity mark.

1

**TAB.1 ASSEMBLY**

STANDARD	
<b>C</b>	Two solenoids centred
<b>E</b>	One solenoid (side A)
<b>F</b>	One solenoid (side B)
Specials (with increased price)	
<b>G</b>	
<b>H</b>	

**TAB.2 VOLTAGES**

AC Voltage	
<b>A</b>	24V 50Hz/60Hz
<b>C</b>	110V 50Hz/60Hz
<b>D</b>	220V 50Hz/60Hz
<b>I</b>	230V 50Hz/60Hz
DC Voltage	
<b>L</b>	12V
<b>M</b>	24V
<b>P</b>	110V
<b>N</b>	48V

The tension symbol is always printed on the nameplate.

**LIMITS OF USE (MOUNTING C-E-F)**

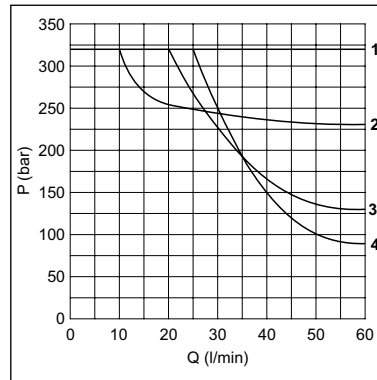

The tests have been carried out with solenoids at operating temperature with a voltage 10% less than rated voltage with a fluid temperature of 40°C. The fluid used was a mineral oil with a viscosity of 46 mm<sup>2</sup>/s at 40°C. The values in the diagram refers to tests carried out with the oil flow in two direction simultaneously (e.g.. from P to A and in the same time B to T).

**In cases where valves 4/2 e 4/3 were used with the flow in one direction only, the limits of use could have variations which may even be negative.**

**NOTE: the operating limits shown are valid for C fittings, E, F.**

Spool type	Curve
01	2
02	1
03	3
04	4
16	1

**TAB.3 SPOOL**

Two solenoids - Assembly C			
Type of spool		Cover	Transit position
<b>01</b>		+	
<b>02</b>		-	
<b>03</b>		+	
<b>04*</b>		-	

One solenoid - Assembly E			
Type of spool		Cover	Transit position
<b>01</b>		+	
<b>02</b>		-	
<b>03</b>		+	
<b>04*</b>		-	
<b>16</b>		+	

One solenoid - Assembly F			
Type of spool		Cover	Transit position
<b>01</b>		+	
<b>02</b>		-	
<b>03</b>		+	
<b>04*</b>		-	
<b>16</b>		+	

(\*) spool with increased price

**PRESSURE DROPS**

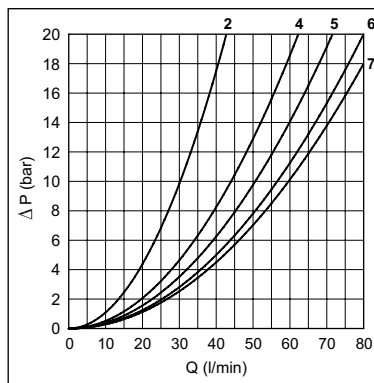

The diagram at the side shows the pressure drop curves for spools during normal usage. The fluid used is a mineral oil with a viscosity of 46 mm<sup>2</sup>/s at 40°C; the tests have been carried out at a fluid temperature of 40°C. For higher flow rates than those in the diagram, the losses will be those expressed by the following formula:

$$\Delta p_1 = \Delta p \times (Q_1/Q)^2$$

Spool type	Connections				
	P→A	P→B	A→T	B→T	P→T
01	5	5	5	5	
02	7	7	7	7	6
03	5	5	6	6	
04	2	2	2	2	4
16	5	5	4	4	

Curve No.

where  $\Delta p$  will be the value for the losses for a specific flow rate Q which can be obtained from the diagram,  $\Delta p_1$  will be the value of the losses for the flow rate Q<sub>1</sub> that is used.

**IDENTIFICATION NAMEPLATE AND MARKING**

**1**

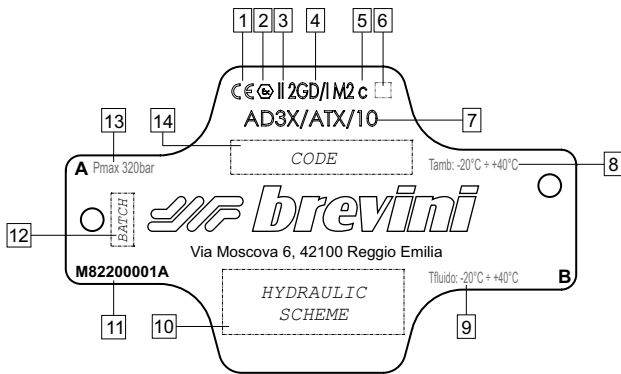

All the solenoid valves are supplied with **identification nameplate and Declaration of conformity** subject to Directive 2014/34/UE.

The identification nameplate bears the main technical specifications related to the functional and constructional characteristics of the valve and **must therefore be kept intact and visible**.

1	CE	Conformity to European Directive
2	Ex	Conformity to ATEX Directive 2014/34/UE
3	II 2 I	Group II (surface places) Group I (mine) Category 2 (high protection)
4	GD M	Explosive atmosphere: GD: presence of gas, vapour or mist and combustible dust M: presence of firedamp atmospheres
5	c	Constructional safety
6	T*	Temperature class: T5 ( $T_{sur} < 100\text{ °C}$ ) T6 ( $T_{sur} < 85\text{ °C}$ ) T6 version (mine)
7	AD3X/ATX/10	Reference to Technical File registered c/o Notified Body

8	T amb	Working ambient temperature: - 20°C ÷ + 40°C series AD3XD
9	T fluid	Working fluid temperature: - 20°C ÷ + 40°C series AD3XD
10	HYDRAULIC SCHEME	Type of hydraulic control performed by the valve
11	M82200001A	Nameplate code
12	BATCH	Reference number of technical order (batch)
13	Pmax 320 bar	Max working pressure
14	CODE	Complete reference number of valve ordering code

**SAFETY INSTRUCTIONS**

- Read the instruction handbook supplied with the valves carefully before installation. All maintenances must be carried out following the instructions given in the manual.
- The AD3XD series valves must be installed and serviced in compliance with plant engineering and maintenance regulations for workplaces classified against the risk of explosion due to the presence of gas and dust and gas (for example: CEI EN 60079-14, CEI EN 60079-17, CEI EN 61241-14, CEI EN 61241-17 or other national regulations/standards).
- The valves must be connected to earth using the special anti-loosening and anti-rotation connection element.
- For all safety aspects related to the use of the coils, consult the relative use and maintenance instructions. The electrical appliances/components must not be opened when live.
- The user must periodically inspect, based on the conditions of use and the substances used, the presence of scale, dirt, the state of wear and tear and correct efficiency of the valves.

**Attention: all installation and maintenance jobs must be carried out by qualified personnel.**

**OVERALL DIMENSIONS**

**1**

**AD3XD...**

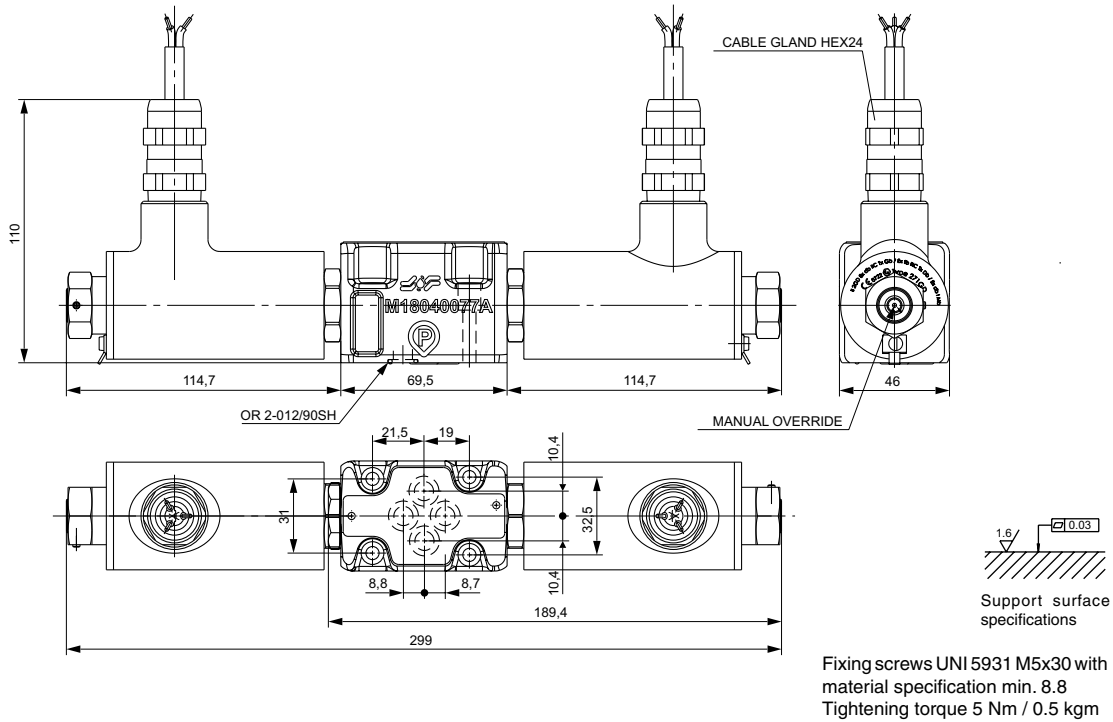

**AD3XD...LE.**

