

# AM3XMP... AMPLIFIER VALVES FOR PROPORTIONAL CONTROL VALVES



AM3XMP...

XP3...

CH. VIII PAGE 26

Max. operating pressure	320 bar
Max. flow	30 l/min
Min. flow	2 l/min
Max. ambient temperature	50° C
Linearity	See diagrams
Max. hysteresis	<3% of nominal value
Repeatability error (150 ÷ 680 mA) XP3...	<3%
Max contamination level	class 8 in accordance with NAS 1638 with filter $\beta_{10}^{375}$
Fluid temperature	-20°C÷75°C
Fluid viscosity	10÷500 mm <sup>2</sup> /s
Weight	0,8 Kg

**Operating specifications are valid for fluids with 33 mm<sup>2</sup>/s viscosity at 40°C, using Aron control units**

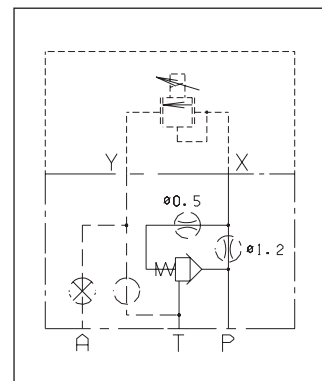

Modular valve type AM.3.XMP... used together with the pressure proportional pilot type XP3.. becomes a pressure control valve piloted by proportional command for rates up to 30 lt/min. The possibility of external drainage on A ensures its correct operation even with back pressure on the discharge side. Other valves types should be ordered separately.

## ORDERING CODE

- AM** Modular valve
- 3** CETOP 3/NG6
- XMP** maximum proportional pressure
- 2** Spring 2 bar (standard)
- 0** Standard dowels (∅ 1,2 dia supply ∅ 0,5 dia damper)
- \*** I = Internal drainage at T  
E = External draining at A
- \*\*** 00 =No variant  
V1 =Viton
- 1** Serial No.

## OVERALL DIMENSIONS

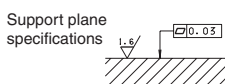
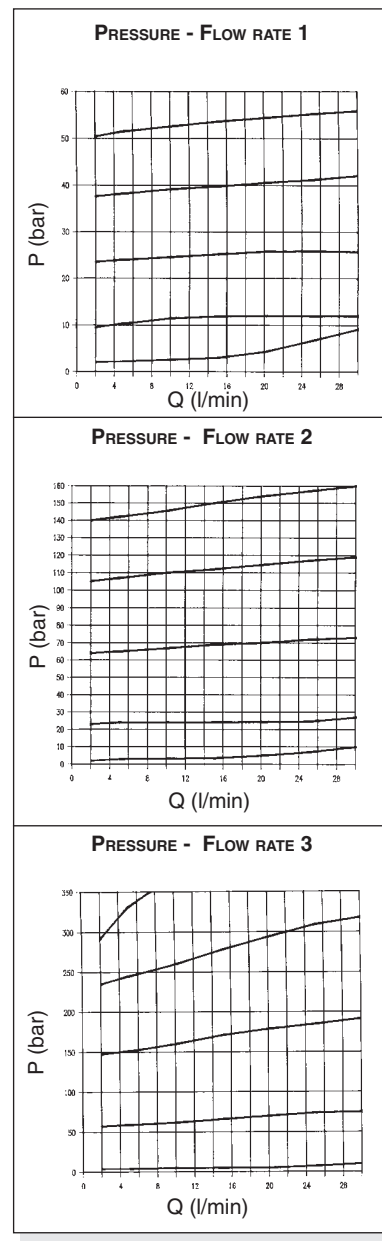
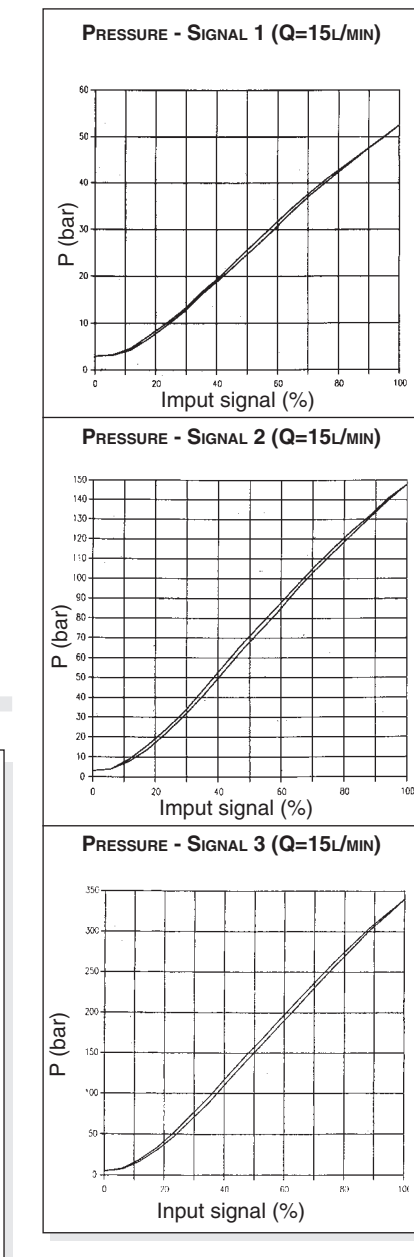
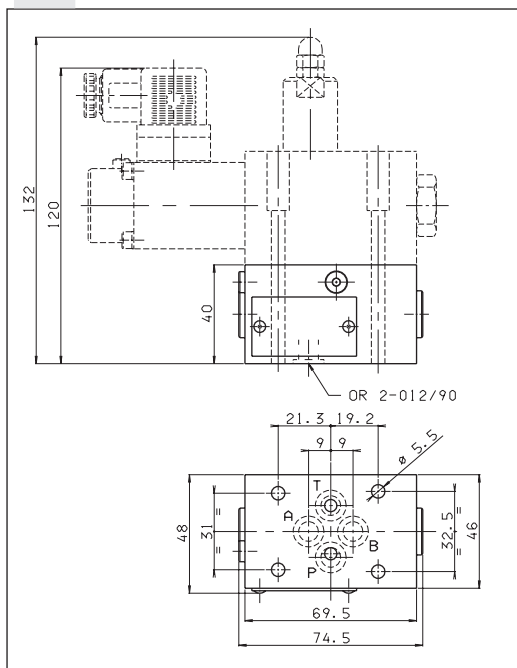

Fixing screws UNI 593 M5x70  
(min. 8.8 material screws are recommended)  
Tightening torque 4 ÷ 5 Nm / 0.4 ÷ 0.5 Kgm