

UPN



UPN

The seal type Aston Seals UPN is the natural further development of the UP seal. It is a high performance all purpose lipseal suitable for both rod and piston which combines the advantage of a highly elastic rubber and the abrasion resistance of polyurethane.

The UPN profile assures a good reaction against shock pressure peaks and low friction in all conditions.

The energizing O-Ring guarantees a good sealing performance in the low pressure range. The material used to produce this seal is a polyurethane compound that ensures excellent properties on wear-resistance, extended service life and resistance against extrusion.

- Good sealing performance as well as at low pressure
- Suitable for both rod and piston
- Economical solution
- Excellent wear-resistance
- Extended service life
- High resistance against extrusion
- Good temperature resistance
- Easy installation without expensive auxiliaries

MATERIAL

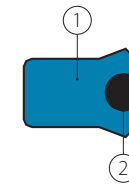

① **Type** Polyurethane
Designation SEALPUR 93
Hardness 93 °ShA

② **Type** Nitril Rubber NBR
Designation RUBSEAL 70
Hardness 70 °ShA

FIELD OF APPLICATION

Pressure
 ≤ 400 bar

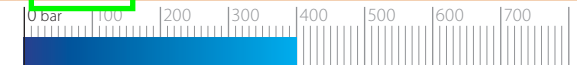

Speed
 ≤ 0.5 m/s



Temperature
 -40°C ÷ +100°C

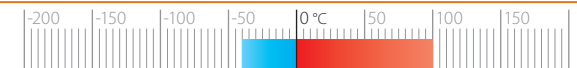

Fluids

Hydraulic oils (mineral oil based)
 For other fluids contact our technical department

SURFACE ROUGHNESS

Dynamic surface
Static surface

Ra ≤ 0.3 µm Rt ≤ 2.5 µm
 Ra ≤ 1.6 µm Rt ≤ 6.3 µm

GAP DIMENSION "g"

The largest gap dimension appearing in operation on the non-pressurised side:

50 bar	1.20 mm	300 bar	0.25 mm
100 bar	0.80 mm	400 bar	0.17 mm
200 bar	0.40 mm		

LEAD-IN CHAMFERS

d	Smin
less 100	5 mm
100÷200	7 mm
over 200	10 mm

After mounting the seal in the housing, verify that the energizing element is positioned correctly.

To avoid damaging the sealing lips during installation, housing must have rounded chamfers. Sharp edges and burrs within the installation area of the seal must be removed.

The above data are maximum values, they may be maintained for short periods and can not be used at the same time simultaneously.

UPN

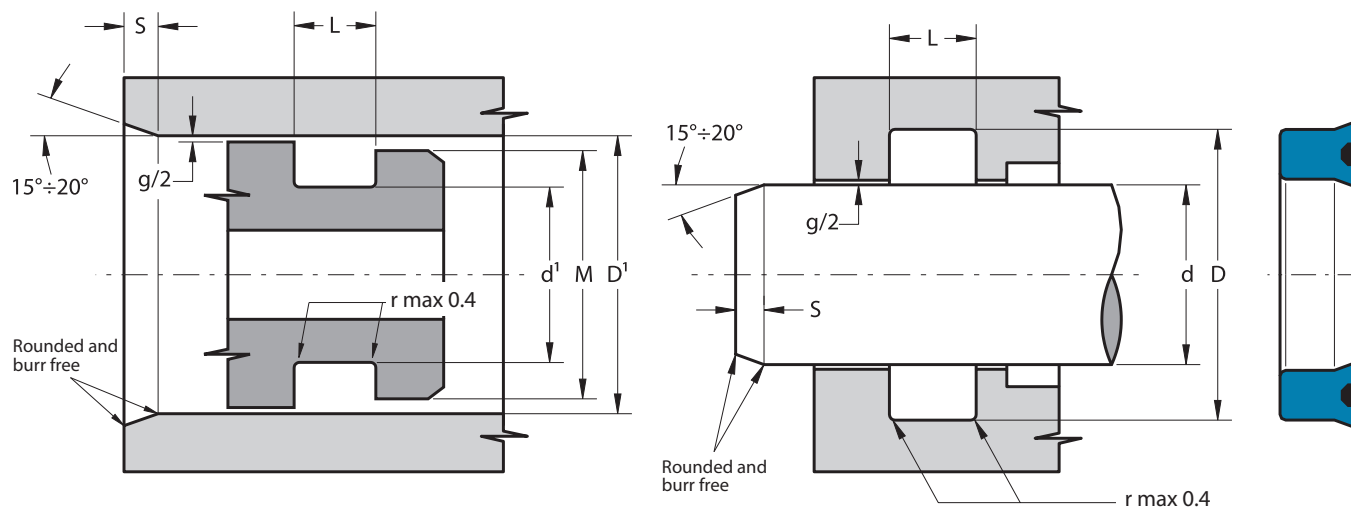

Part.	$d_{f7}^{1 f8}$	$D_{H10}^{1 H10}$	$L_{+0.25}$	M
UPN 5 17 9	5	17	10.0	14.0
UPN 8 18 9	8	18	10.0	15.5
UPN 10 18 5	10	18	6.0	16.0
UPN 10 20 8	10	20	9.0	17.5
UPN 10 22 8	10	22	9.0	19.0
UPN 12 22 5	12	22	6.0	19.5
UPN 12 22 7	12	22	8.0	19.5
UPN 12 22 8	12	22	9.0	19.5
UPN 12 24 8	12	24	9.0	21.0
UPN 14 24 8	14	24	9.0	21.5
UPN 14 27 7	14	27	8.0	24.0
UPN 15 21.5 4.5	15	21.5	5.0	20.0
UPN 15 25 8	15	25	9.0	22.5
UPN 15 25 10	15	25	11.0	22.5
UPN 16 24 8	16	24	9.0	22.0
UPN 16 26 5	16	26	6.0	23.5
UPN 16 26 8	16	26	9.0	23.5
UPN 16 28 6	16	28	7.0	25.0
UPN 16 28 9	16	28	10.0	25.0
UPN 16 32 8	16	32	9.0	28.0
UPN 17 25 4	17	25	4.5	23.0
UPN 17 25 6	17	25	7.0	23.0
UPN 17 27 6.5	17	27	7.5	24.5
UPN 18 28 8	18	28	9.0	25.5

Part.	$d_{f7}^{1 f8}$	$D_{H10}^{1 H10}$	$L_{+0.25}$	M
UPN 18 30 8	18	30	9.0	27.0
UPN 20 28 5.7	20	28	6.2	26.0
UPN 20 28 7	20	28	8.0	26.0
UPN 20 29 5	20	29	5.5	27.0
UPN 20 30 7	20	30	8.0	27.5
UPN 20 30 8	20	30	9.0	27.5
UPN 20 30 10	20	30	11.0	27.5
UPN 20 32 7.5	20	32	8.5	29.0
UPN 20 35 9	20	35	10.0	31.5
UPN 20 40 10	20	40	11.0	35.0
UPN 22 32 8	22	32	9.0	29.5
UPN 22 32 10	22	32	11.0	29.5
UPN 22 35 10	22	35	11.0	32.0
UPN 22 40 10	22	40	11.0	35.5
UPN 24 32 6	24	32	7.0	30.0
UPN 24 32 7	24	32	8.0	30.0
UPN 25 33 6	25	33	7.0	31.0
UPN 25 35 5	25	35	5.5	32.5
UPN 25 35 8	25	35	9.0	32.5
UPN 25 35 10	25	35	11.0	32.5
UPN 25 38 8	25	38	9.0	35.0
UPN 25 38 10	25	38	11.0	35.0
UPN 25 40 7	25	40	8.0	36.0
UPN 25 40 10	25	40	11.0	36.0

Part.	$d_{f7}^{1 f8}$	$D_{H10}^{1 H10}$	$L_{+0.25}$	M
UPN 27 36.5 6.8	27	36.5	7.8	34.0
UPN 28 38 7	28	38	8.0	35.5
UPN 28 38 8	28	38	9.0	35.5
UPN 28 38 10	28	38	11.0	35.5
UPN 28 40 10	28	40	11.0	37.0
UPN 30 40 5	30	40	5.5	37.5
UPN 30 40 6	30	40	7.0	37.5
UPN 30 40 10	30	40	11.0	37.5
UPN 30 42 9	30	42	10.0	39.0
UPN 30 42 10	30	42	11.0	39.0
UPN 30 45 10	30	45	11.0	41.5
UPN 30 50 10	30	50	11.0	45.0
UPN 30 50 12	30	50	13.0	45.0
UPN 32 40 5.5	32	40	6.0	38.0
UPN 32 40 8	32	40	9.0	38.0
UPN 32 42 10	32	42	11.0	39.5
UPN 32 45 10	32	45	11.0	42.0
UPN 34 45 7	34	45	8.0	42.5
UPN 34 45 9	34	45	10.0	42.5
UPN 35 43 6	35	43	7.0	41.0
UPN 35 45 5	35	45	5.5	42.5
UPN 35 45 6	35	45	7.0	42.5
UPN 35 45 7	35	45	8.0	42.5
UPN 35 45 8	35	45	9.0	42.5

UPN

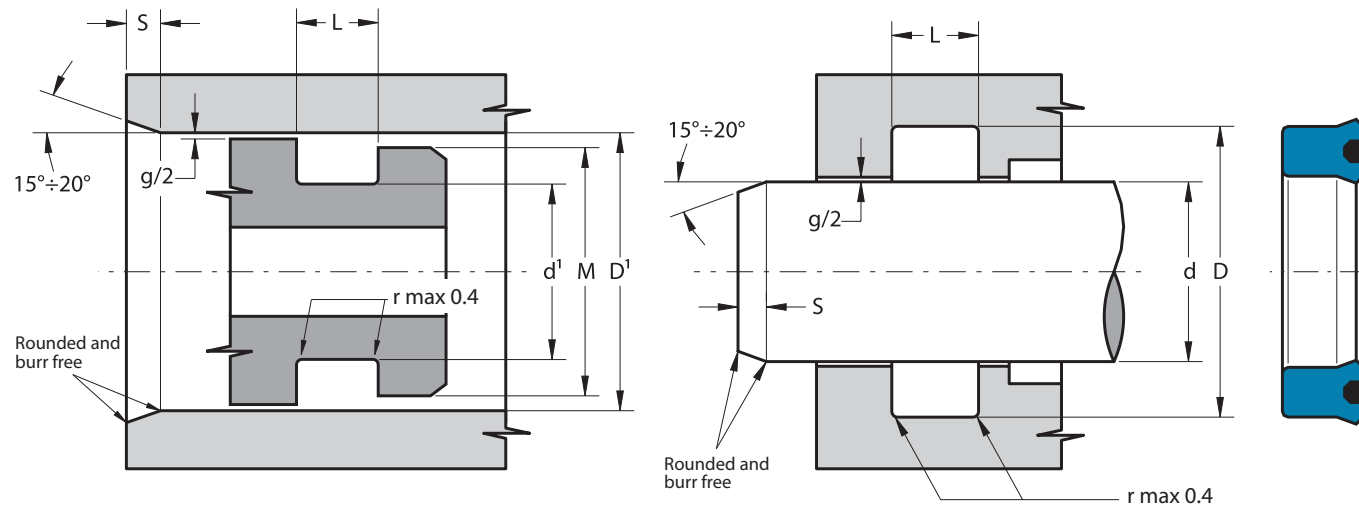

Part.	d ^{1 f8} d _{f7}	D ^{1 H10} D _{H10}	L ^{+0.25}	M
UPN 35 45 10	35	45	11.0	42.5
UPN 35 48 10	35	48	11.0	45.0
UPN 35 50 10	35	50	11.0	46.5
UPN 35 55 10	35	55	11.0	50.0
UPN 35 55 12	35	55	13.0	50.0
UPN 36 46 7	36	46	8.0	43.5
UPN 36 48 8	36	48	9.0	45.0
UPN 38 46 6.5	38	46	7.5	44.0
UPN 38 50 9	38	50	10.0	47.0
UPN 38 55 10	38	55	11.0	51.0
UPN 38 58 10	38	58	11.0	53.0
UPN 40 48 5.8	40	48	6.3	46.0
UPN 40 48 8	40	48	9.0	46.0
UPN 40 50 5	40	50	5.5	47.5
UPN 40 50 6	40	50	7.0	47.5
UPN 40 50 6.5	40	50	7.5	47.5
UPN 40 50 8	40	50	9.0	47.5
UPN 40 50 10	40	50	11.0	47.5
UPN 40 55 10	40	55	11.0	51.5
UPN 40 60 10	40	60	11.0	55.0
UPN 40 60 13	40	60	14.0	55.0
UPN 42 50 6	42	50	7.0	48.0
UPN 42 50 8	42	50	9.0	48.0
UPN 42 52 9	42	52	10.0	49.5

Part.	d ^{1 f8} d _{f7}	D ^{1 H10} D _{H10}	L ^{+0.25}	M
UPN 42 62 12	42	62	13.0	57.0
UPN 45 53 6.5	45	53	7.5	51.0
UPN 45 55 6	45	55	7.0	52.5
UPN 45 55 6.5	45	55	7.5	52.5
UPN 45 55 10	45	55	11.0	52.5
UPN 45 56 7	45	56	8.0	53.5
UPN 45 60 10	45	60	11.0	56.5
UPN 45 63 10	45	63	11.0	58.5
UPN 45 65 10	45	65	11.0	60.0
UPN 45 65 12	45	65	13.0	60.0
UPN 48 58 10	48	58	11.0	55.5
UPN 50 60 5	50	60	5.5	57.5
UPN 50 60 6	50	60	7.0	57.5
UPN 50 60 7	50	60	8.0	57.5
UPN 50 60 10	50	60	11.0	57.5
UPN 50 60 11	50	60	12.0	57.5
UPN 50 62 9	50	62	10.0	59.0
UPN 50 63 6	50	63	7.0	60.0
UPN 50 65 7	50	65	8.0	61.5
UPN 50 65 10	50	65	11.0	61.5
UPN 50 70 10	50	70	11.0	65.0
UPN 50 70 12	50	70	13.0	65.0
UPN 52 62 12	52	62	13.0	59.5
UPN 53 63 6.5	53	63	7.5	60.5

Part.	d ^{1 f8} d _{f7}	D ^{1 H10} D _{H10}	L ^{+0.25}	M
UPN 55 65 6	55	65	7.0	62.5
UPN 55 65 10	55	65	11.0	62.5
UPN 55 65 12	55	65	13.0	62.5
UPN 55 70 12	55	70	13.0	66.5
UPN 55 75 12	55	75	13.0	70.0
UPN 55 80 12	55	80	13.0	74.0
UPN 56 66 5	56	66	5.5	63.5
UPN 56 66 6	56	66	7.0	63.5
UPN 60 70 5	60	70	5.5	67.5
UPN 60 70 6	60	70	7.0	67.5
UPN 60 70 8	60	70	9.0	67.5
UPN 60 70 10	60	70	11.0	67.5
UPN 60 70 12	60	70	13.0	67.5
UPN 60 71 7	60	71	8.0	68.0
UPN 60 75 10	60	75	11.0	71.5
UPN 60 75 12	60	75	13.0	71.5
UPN 60 80 10	60	80	11.0	75.0
UPN 60 80 12	60	80	13.0	75.0
UPN 60 80 18	60	80	19.0	75.0
UPN 63 73 6	63	73	7.0	70.5
UPN 63 75 10	63	75	11.0	72.0
UPN 63 78 10	63	78	11.0	74.5
UPN 65 75 6	65	75	7.0	72.5
UPN 65 75 12	65	75	13.0	72.5

UPN

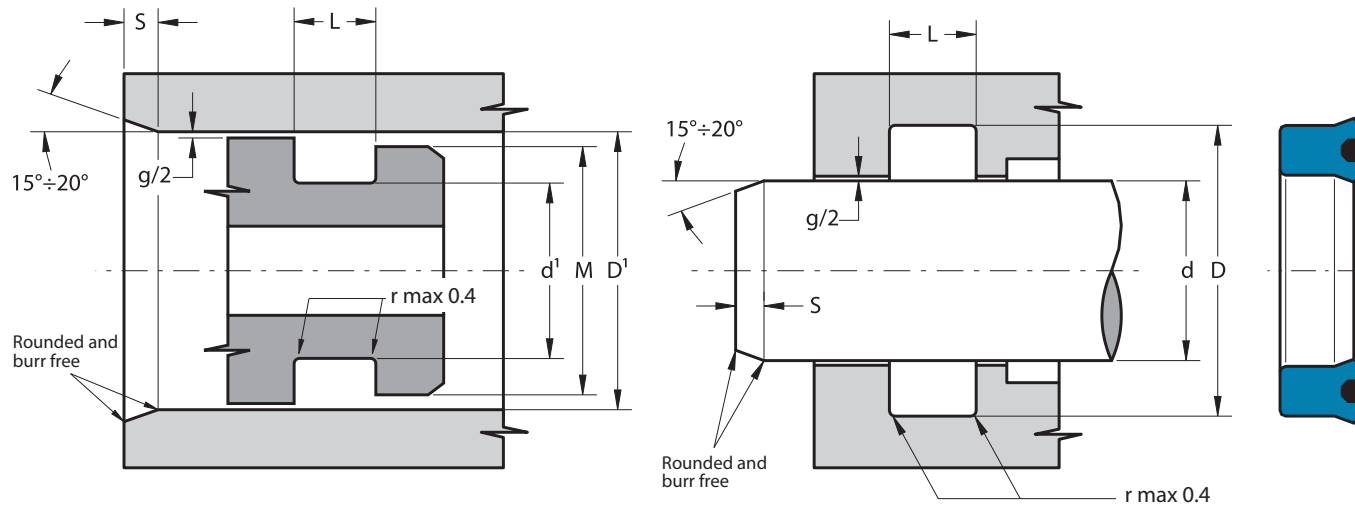

Part.	$d^{1 f8}$ d^{f7}	$D^{1 H10}$ D^{H10}	$L^{+0.25}$	M
UPN 65 80 10	65	80	11.0	76.5
UPN 65 80 11	65	80	12.0	76.5
UPN 65 80 12	65	80	13.0	76.5
UPN 65 85 12	65	85	13.0	80.0
UPN 67 77 10	67	77	11.0	74.5
UPN 68 92.4 14	68	92.4	15.0	86.5
UPN 70 75 3.5	70	75	4.1	73.5
UPN 70 80 5	70	80	6.0	77.5
UPN 70 80 6	70	80	7.0	77.5
UPN 70 80 8	70	80	9.0	77.5
UPN 70 80 10	70	80	11.0	77.5
UPN 70 80 12	70	80	13.0	77.5
UPN 70 85 11	70	85	12.0	81.5
UPN 70 85 12	70	85	13.0	81.5
UPN 70 90 12	70	90	13.0	85.0
UPN 75 85 6	75	85	7.0	82.5
UPN 75 85 12	75	85	13.0	82.5
UPN 75 90 7.5	75	90	8.5	86.5
UPN 75 90 10	75	90	11.0	86.5
UPN 75 90 12	75	90	13.0	86.5
UPN 75 95 10	75	95	11.0	90.0
UPN 75 95 12	75	95	13.0	90.0
UPN 75 95 13.5	75	95	14.5	90.0
UPN 75 95 14.5	75	95	15.5	90.0

Part.	$d^{1 f8}$ d^{f7}	$D^{1 H10}$ D^{H10}	$L^{+0.25}$	M
UPN 77.5 87.5 10	77.5	87.5	11.0	85.0
UPN 80 90 5	80	90	6.0	87.5
UPN 80 90 6	80	90	7.0	87.5
UPN 80 90 8	80	90	9.0	87.5
UPN 80 90 10	80	90	11.0	87.5
UPN 80 90 12	80	90	13.0	87.5
UPN 80 95 12	80	95	13.0	91.5
UPN 80 100 9.5	80	100	10.5	95.0
UPN 80 100 12	80	100	13.0	95.0
UPN 85 95 8.5	85	95	9.5	92.5
UPN 85 95 12	85	95	13.0	92.5
UPN 85 100 9	85	100	10.0	96.5
UPN 85 100 10	85	100	11.0	96.5
UPN 85 100 12	85	100	13.0	96.5
UPN 85 105 12	85	105	13.0	100.0
UPN 90 100 8	90	100	9.0	97.5
UPN 90 100 12	90	100	13.0	97.5
UPN 90 105 12	90	105	13.0	101.5
UPN 90 110 12	90	110	13.0	105.0
UPN 90 115 12	90	115	13.0	109.0
UPN 90 115 15	90	115	16.0	109.0
UPN 95 110 9	95	110	10.0	106.5
UPN 95 110 12	95	110	13.0	106.5
UPN 95 115 12	95	115	13.0	110.0

Part.	$d^{1 f8}$ d^{f7}	$D^{1 H10}$ D^{H10}	$L^{+0.25}$	M
UPN 100 115 9	100	115	10.0	111.5
UPN 100 115 12	100	115	13.0	111.5
UPN 100 120 12	100	120	13.0	115.0
UPN 100 125 12	100	125	13.0	119.0
UPN 100 125 15	100	125	16.0	119.0
UPN 105 120 8	105	120	9.0	116.5
UPN 105 120 11	105	120	12.0	116.5
UPN 105 120 15	105	120	16.0	116.5
UPN 105 125 12	105	125	13.0	120.0
UPN 105 125 15	105	125	16.0	120.0
UPN 110 125 9	110	125	10.0	121.5
UPN 110 125 12	110	125	13.0	121.5
UPN 110 125 15	110	125	16.0	121.5
UPN 110 130 15	110	130	16.0	125.0
UPN 115 135 15	115	135	16.0	130.0
UPN 120 140 15	120	140	16.0	135.0
UPN 125 140 9	125	140	10.0	136.5
UPN 125 140 11	125	140	12.0	136.5
UPN 125 140 15	125	140	16.0	136.5
UPN 125 145 15	125	145	16.0	140.0
UPN 130 145 12	130	145	13.0	141.5
UPN 130 150 15	130	150	16.0	145.0
UPN 140 155 9	140	155	10.0	151.5
UPN 140 160 12	140	160	13.0	155.0

UPN

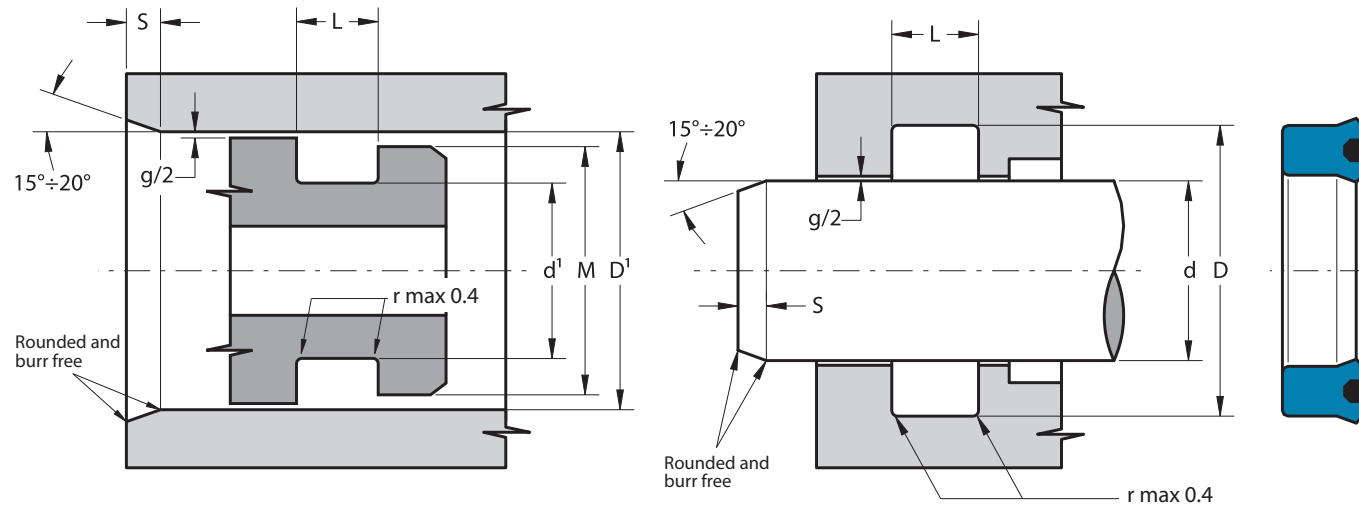

Part.	$d_{f7}^{+0.18}$	$D_{H10}^{+0.10}$	$L_{+0.25}$	M
UPN 140 160 15	140	160	16.0	155.0
UPN 145 165 15	145	165	16.0	160.0
UPN 150 170 15	150	170	16.0	165.0
UPN 160 175 12	160	175	13.0	171.5
UPN 160 180 15	160	180	16.0	175.0
UPN 170 190 12	170	190	13.0	185.0
UPN 170 190 15	170	190	16.0	185.0
UPN 175 200 15	175	200	16.0	194.0
UPN 180 200 15	180	200	16.0	195.0
UPN 180 205 18	180	205	19.0	199.0
UPN 190 210 15	190	210	16.0	205.0
UPN 200 220 12	200	220	13.0	215.0
UPN 200 220 15	200	220	16.0	215.0
UPN 200 225 18	200	225	19.0	219.0
UPN 220 250 18	220	250	19.0	242.5

Part.	$d_{f7}^{+0.18}$	$D_{H10}^{+0.10}$	$L_{+0.25}$	M
-------	------------------	-------------------	-------------	---

Inch sizes

UPN 1500 2000 0250	38.10	50.80	7.35	48.0
UPN 2000 2500 0250	50.80	63.50	7.35	60.5
UPN 2000 2625 0562	50.80	66.68	14.78	61.6
UPN 2125 2625 0406	53.97	66.68	11.00	63.5
UPN 2250 2625 0375	57.15	66.68	10.50	64.5
UPN 2500 3250 0620	63.50	82.55	16.75	78.0
UPN 2625 3000 0187	66.68	76.20	5.25	74.0
UPN 3000 3625 0562	76.20	92.08	14.78	87.1
UPN 3000 3750 0620	76.20	95.25	16.75	90.5
UPN 3500 3875 0375	88.90	98.43	10.50	96.0
UPN 3500 4000 0375	88.90	101.60	10.50	98.6
UPN 3500 4250 0620	88.90	107.95	16.75	103.0
UPN 3875 4250 0187	98.43	107.95	5.25	105.5
UPN 5250 6000 0620	133.36	152.40	16.75	147.5
UPN 6250 7000 0620	158.75	177.80	16.75	173.0
UPN 6500 7500 0765	165.10	190.50	20.40	184.0
UPN 7000 8000 0750	177.80	203.20	20.10	197.0

