

PM 6-12-25-45 e-s

without release hand knob
double acting hand pump for single acting cylinder
for fixing to tank

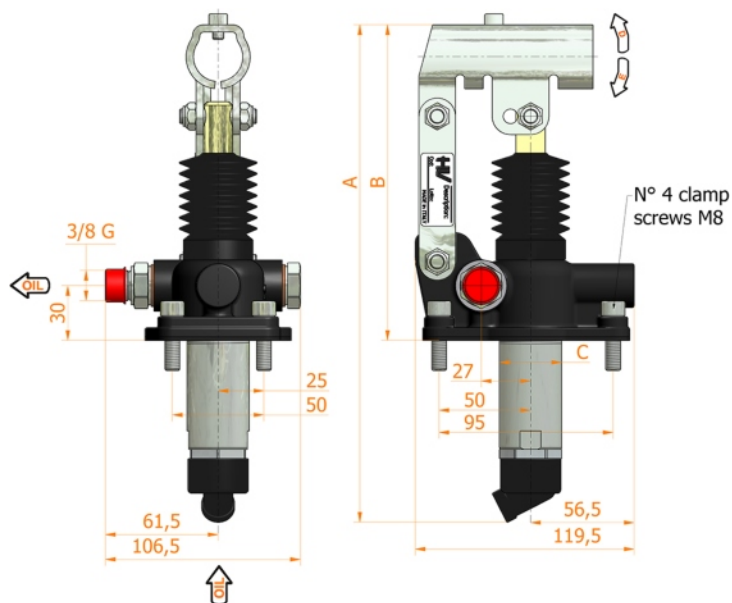
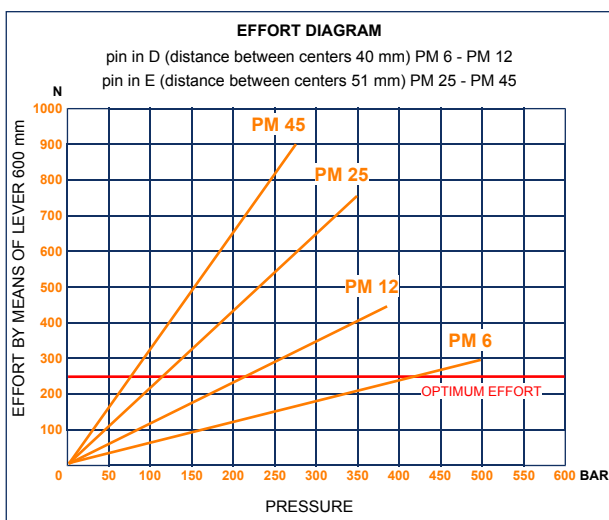

Specifications:

- Cast iron body
- Piston treated with Niploy
- White zinc plated support lever
- Lever connection Ø 27
- White zinc plated external parts
- Standard colour black
- Oil tank mounting kit included

DISPLACEMENT cm ³	A mm	B mm	C mm	D °	E °	ACTUAL DISPLACEMENT cm ³	PRESSURE BAR		MASS KG	CODE WITHOUT BELLOWS	CODE WITH BELLOWS
							OPTIMAL	MAX			
6	253	166	34	26	31	6,970	420	500	2,900	6049.0110	6049.0118
12	253	166	34	26	31	12,095	220	380	2,900	6050.0110	6050.0118
25	273	172	34	30	30	25,280	120	350	2,950	6051.0110	6051.0118
45	283	172	40	45	33	44,532	80	280	3,000	6052.0110	6052.0118