

PM2V 5/80 Lm-M-s

with release hand knob
 with exclusion lever for the 1st speed
 with pressure-gauge
 two speed hand pump for a single acting cylinder
 for fixing to tank

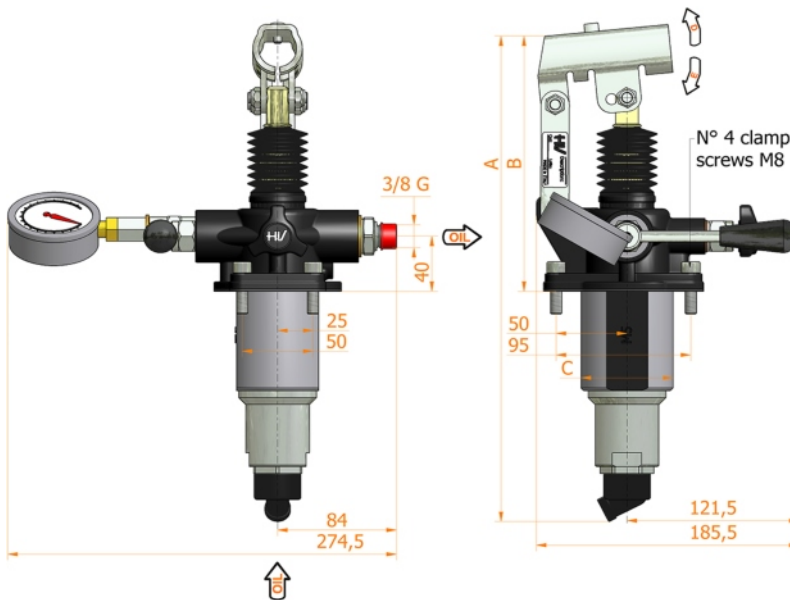
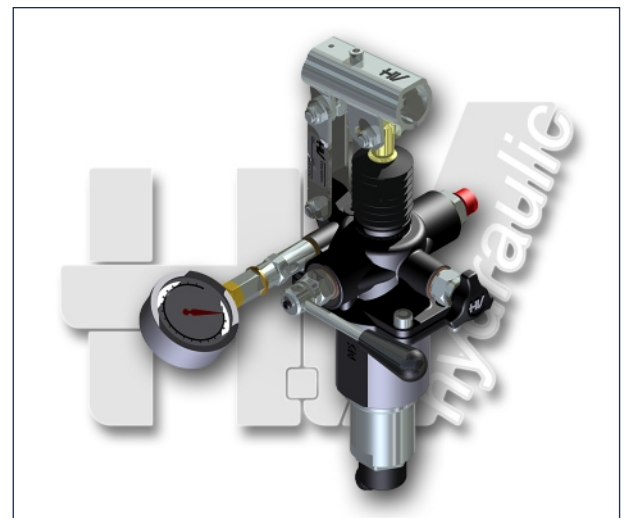
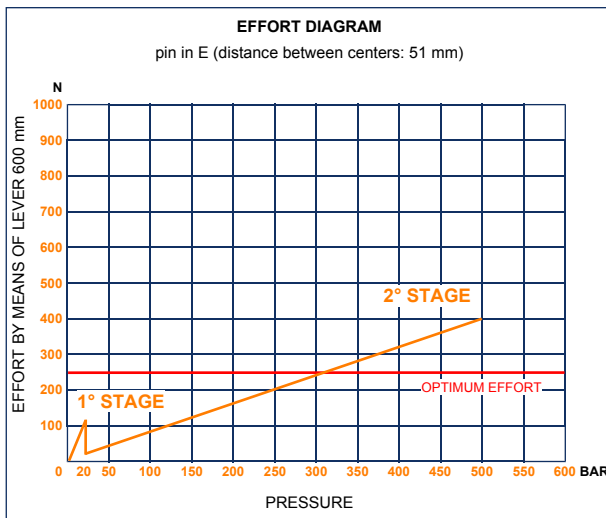
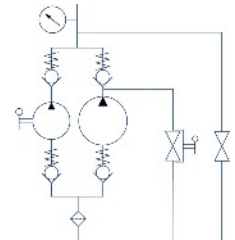

Specifications:

- Cast iron body
- Piston treated with Niploy
- White zinc plated support lever
- Lever connection Ø 27
- White zinc plated external parts
- Standard colour black
- Oil tank mounting kit included

DISPLACEMENT cm ³	A mm	B mm	C mm	D °	E °	DISPLACEMENT cm ³		PRESSURE BAR		MASS KG	CODE WITHOUT BELLOWS	CODE WITH BELLOWS
						STAGE 1	STAGE 2	STAGE 1	STAGE 2			
5-80	354	185	65	30	32	80,588	5,036	20	500	6,200	6071.0103	6071.0130