

PMSE 8-15 e-s

without release hand knob
single acting hand pump for a single acting cylinder
for fixing to tank

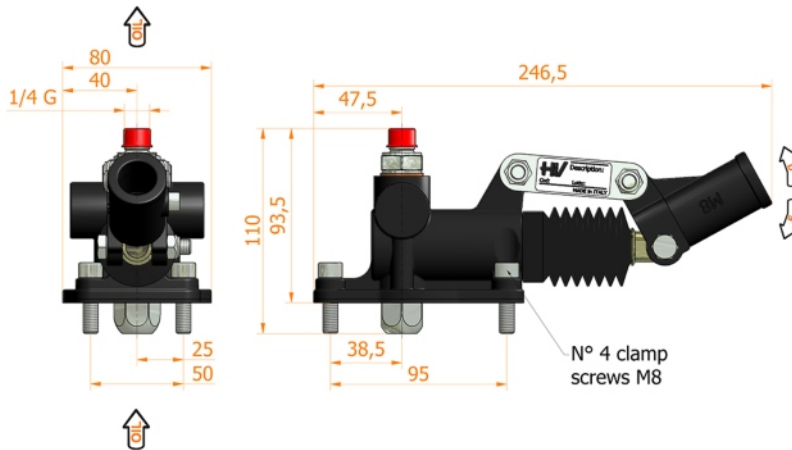
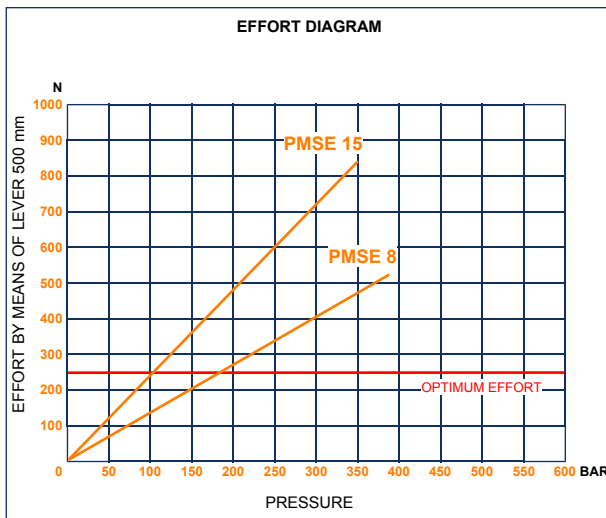

Specifications:

- Cast iron body
- Piston treated with Niploy
- Iron cast support lever
- Lever connection Ø 20
- White zinc plated external parts
- Standard colour black
- Oil tank mounting kit included

DISPLACEMENT cm ³	A mm	B mm	C mm	D °	E °	ACTUAL DISPLACEMENT cm ³	PRESSURE BAR		MASS KG	CODE WITHOUT BELLOWS	CODE WITH BELLOWS
							OPTIMAL	MAX			
8	--	--	--	30	26	8,042	180	380	3,200	6065.0012	6065.0039
15	--	--	--	30	26	15,205	110	350	3,200	6066.0012	6066.0039