

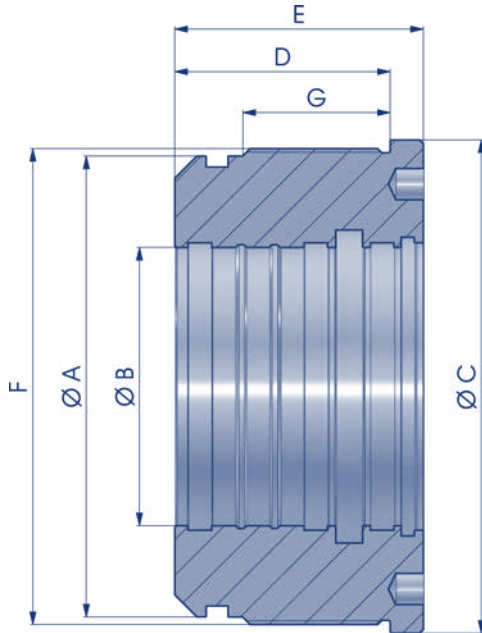

TESTATA S300  
HEAD S300 KOPF S300  
TÊTE S300 CABEZA S300



NEW	COD.	A	B	C	D	E	F	G	Kg
	NBT210180080	180	80	209	92	110	M188X2.5	58	17,07
	NBT210180090	180	90	209	92	110	M188X2.5	58	15,75
	NBT210180100	180	100	209	92	110	M188X2.5	58	14,55
	NBT210180120	180	120	209	92	110	M188X2.5	58	11,50
	NBT220200090	200	90	219	92	110	M208X2.5	58	20,02
	NBT220200100	200	100	219	92	110	M208X2.5	58	18,92
	NBT220200120	200	120	219	92	110	M208X2.5	58	16,00
	NBT220200140	200	140	219	92	110	M208X2.5	58	12,55
	NBT250220100	220	100	249	104	122	M228X2.5	70	27,50
	NBT250220110	220	110	249	104	122	M228X2.5	70	26,07
	NBT250220120	220	120	249	104	122	M228X2.5	70	24,40
	NBT250220150	220	150	249	104	122	M228X2.5	70	18,38
	NBT250220160	220	160	249	104	122	M228X2.5	70	15,92
	NBT270250120	250	120	268	117	135	M258X2.5	80	37,35
	NBT270250150	250	150	268	117	135	M258X2.5	80	30,80

Materiale di produzione : Ghisa GG 25  
Production material : Cast iron GG 25  
Werkstoff : Gusseisen GG 25  
Matériel de production : Fonte grise GG 25  
Material de fabricación : Hierro fundido GG 25