



60
kN



-50
kN



30
kN

-25
kN

1850
nm

37
kg

25
l/min

Hydraulic rotator FHR 6LD1/68 is ideal for professional use in forestry, agriculture, road and building construction, recycling industry, general cargo and material handling.

Rotator's upper mount is applied in FORK form factor of the knuckle joint. Robust and tough built to withstand even overloads. The fork width (between fork ends) is common standard width 80mm and the knuckle pin diameter 35mm.

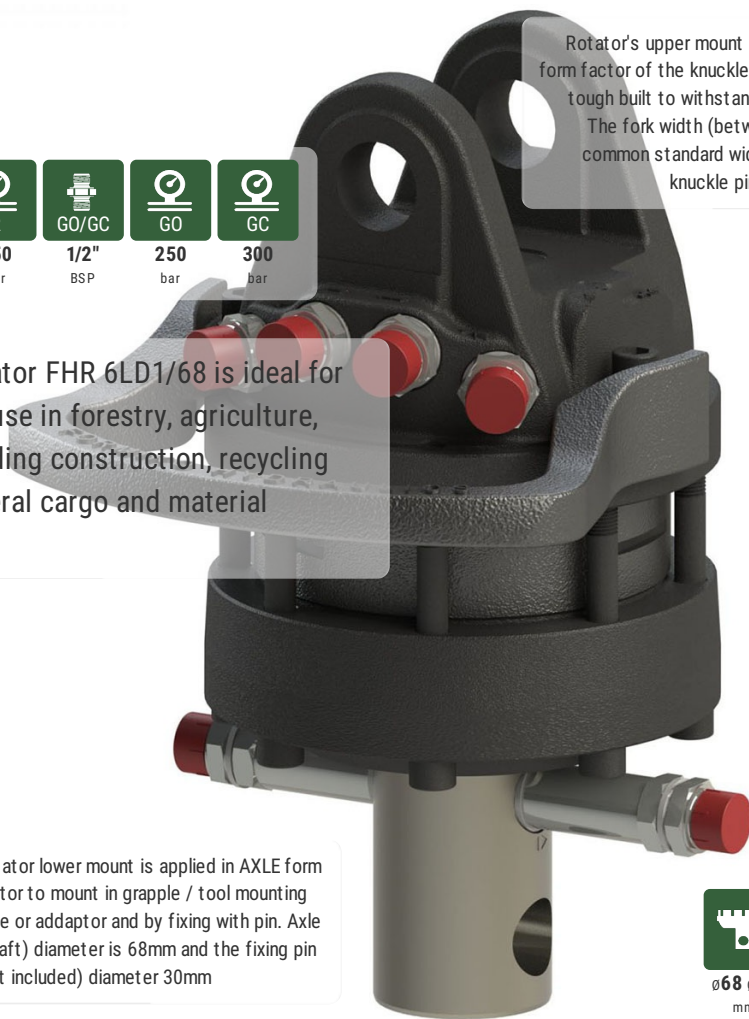

Rotator lower mount is applied in AXLE form factor to mount in grapple / tool mounting tube or adaptor and by fixing with pin. Axle (shaft) diameter is 68mm and the fixing pin (not included) diameter 30mm

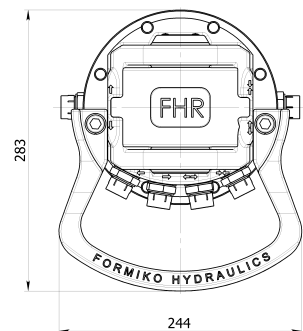
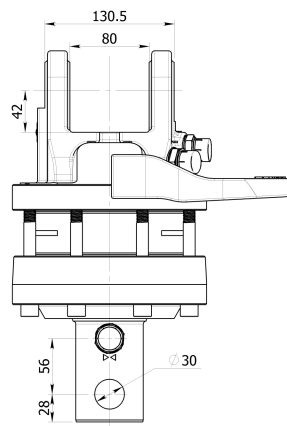
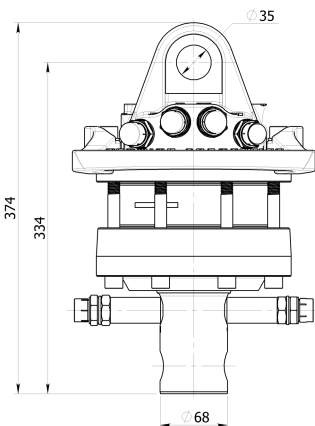

On request by special conditions there are metric nipples available for rotator FHR 6LD1/68



Hydraulic rotator FHR 6LD1/68 is ideal for professional use in forestry, agriculture, road and building construction, recycling industry, general cargo and material handling.



Rotator's upper mount is applied in FORK form factor of the knuckle joint. Robust and tough built to withstand even overloads. The fork width (between fork ends) is common standard width 80mm and the knuckle pin diameter 35mm.



Rotator lower mount is applied in AXLE form factor to mount in grapple / tool mounting tube or addaptor and by fixing with pin. Axle (shaft) diameter is 68mm and the fixing pin (not included) diameter 30mm



Rotator FHR 6LD1/68 based on reliable vane type hydraulic motor which delivers torque up to 1850Nm at 25MPa.



Fomiko Hydraulics rotator FHR 6LD1/68 is equipped with double bearings to withstand both tensional and pushing loads.



Fomoko rotator FHR 6LD1/68 is compatible with FHL 02 series links.



Rotator for shipping is packed in compact solid cardboard box with dimensions 400x250x250mm.



We providing TWO year warranty for this rotator.

On request by special conditions there are metric nipples available for rotator FHR 6LD1/68

